



IWSL6040CA

60CM 4 ZONE BUILT-IN INDUCTION COOKTOP

FEATURES & BENEFITS



INDUCTION TECHNOLOGY

Induction technology heats the pan, not the hob, reducing energy dispersion as well as achieving faster and energy-efficient cooking.



STOP & GO

Suspend the cooking process if you're interrupted then re-start again at the same temperature in an instant with the Stop & Go function.



BLACK CERAMIC GLASS

A completely smooth cooking surface makes the cooktop extremely easy to clean with just a wipe.



CHILD LOCK

Featuring a Child Lock function to prevent toddlers and children from accidentally using the hob.



WARRANTY

5 Year warranty on parts and labour.

TECHNICAL SPECIFICATIONS

TYPE	60cm Built-in Induction Hob
COOKING ZONES	4
COLOR / FINISH	Black Ceramic Glass
CONTROL	Touch Control
LOCATION OF CONTROL PANEL	Front
PRODUCT NET WEIGHT	8.4kg
PRODUCT DIMENSION	W 590mm x H 56mm x D 520mm
CUT-OUT DIMENSION	W 560mm x D 500mm
FUNCTIONS	Stop & Go Function
FEATURES	Individual Timer, Auto switch safety, Child Lock, Residual heat indicator, Auto-pan detection
TOTAL POWER	2400W (Power Share)
LEFT, FRONT ZONE	2,000W
LEFT, REAR ZONE	1,500W
RIGHT FRONT ZONE	1,500W
RIGHT REAR ZONE	2,000W
POWER SETTING	9 levels
ENERGY INPUT	Electric
POWER VOLTAGE	220-240V / 50-60Hz
LENGTH OF POWER CORD	110cm (10AMP Australian Plug)
PACKAGING DIMENSION	W 635mm x H 113mm x D 568mm
GROSS WEIGHT	10kg
COUNTRY OF ORIGIN	Asia
WARRANTY	5 Years

INSTALLATION GUIDE

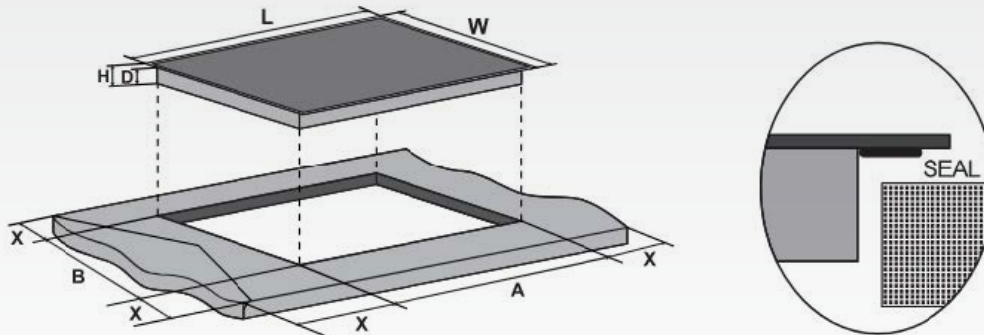

INDICATION	L	W	H	D	A	B	X
DIMENSION	590mm	520mm	56mm	52mm	560mm	500mm	50mm

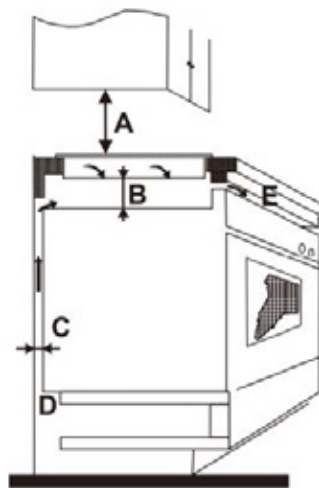

INDICATION	A	B	C	D	E
DIMENSION	760mm (min.)	50mm (min.)	20mm (min.)	20mm (Air inlet min.)	5mm (Air outlet min.)